

# DYNAMIC SIMULATION OF THE NOVEL XLEV MAGNETICALLY LEVITATED CONVEYOR VEHICLE

**Jan Van Goethem, Gerhard Henneberger**

Aachen University of Technology, Institute of Electrical Machines  
Schinkelstraße 4, 52056 Aachen, Germany  
jan.vangoethem@iem.rwth-aachen.de

## ABSTRACT

In this paper a novel magnetic levitation system XLEV is presented. It is designed as a bearing system for a conveyor vehicle with very high demands on operational availability and conveyor speed combined with a minimum need for maintenance. After presentation of the mode of operation a simulation environment is described for the analysis of the dynamic behaviour. Appropriate control algorithms together with the special features of the XLEV system enable a magnetically levitated vehicle to pass a passive switch without interrupting the levitation state. Simulation results prove this remarkable feature.

## 1 INTRODUCTION

Businesses that ship, receive, store, handle, manufacture or distribute as a core part of their mission know that a conveyor system can become nothing less than their operation's physical nervous system; the one thing that must operate for everything else to function. High operational availability combined with low operation costs are therefore the mean demands on modern conveyor systems.

Conventional conveyor vehicles are based on the wheel-rail concept and therefore suffer from friction. As the demand for expensive maintenance increases exponentially with the conveyor speed, its upper limit is strictly limited. A typical value is 10m/s.

For conveying applications with a demand for higher conveyor speeds a new conveyor technology must be used. At the Institute of Electrical Machines research is done about such a new generation of conveyor system, which is based on Decision Coded Vehicles. Its nominal conveyor speed is 15m/s on a straight track. In order to eliminate the problems due to friction both the propulsion and the suspension of the vehicle are based on contactless technology. The vehicle is suspended with a low-loss hybrid-excited

magnetic bearing system. Linear motors (short stator type homopolar motors) for propulsion and an inductive energy transmission modules round up the completely contactless technology. Each vehicle, equipped with on-board computer and route manager, behaves as an autonomous unit which carries a load from one point in the system to another. Depending on the current status of the track, the vehicle by itself will decide which way is best suitable in order to get the load as fast as possible to its destination.

In order to maintain a high conveyor throughput, the curve speed must be as high as possible. Furthermore, an appropriate switch concept must be found. Here, a passive switch concept is preferred, because the switching time of an active switch may be too big and can therefore limit the throughput. In order to guarantee a full contactless operation of the new conveyor system, a new magnetic bearing system was developed, which allows the vehicle to pass a passive switch without interrupting its levitation state. This novel magnetic bearing system is called XLEV and stands for eXtended LEVitation [1].

First the novel XLEV system is presented. The mode of operation is described in detail. A few important design aspects are highlighted. After presentation of the simulation environment, a standard case study is defined. The corresponding simulation results prove the usefulness of XLEV concept.

## 2. THE XLEV SYSTEM

The novel levitation system comprehends both elements of a EMS type suspension system: 1) the electromagnets: conventional EMS type maglev vehicles are equipped with electromagnets mounted underneath the guideway, which pull the vehicle towards the reaction rail. Besides these electromagnets, the XLEV system also contains electromagnets mounted above the guideway which can actively push

the vehicle downwards. These are the so called stabilising magnets 2) the reaction rail and track: as being described below, the constraints on the dimensions of the track fix the dimensions of the vehicle and the electromagnets.

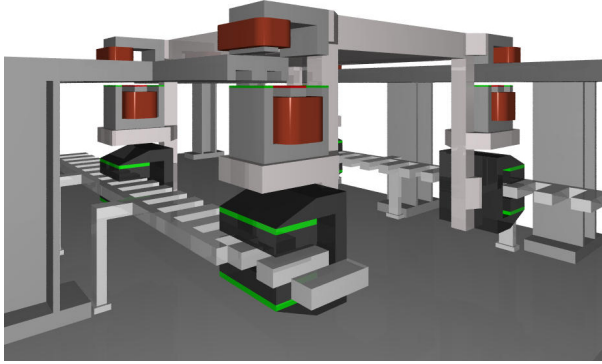

FIGURE 1: The XLEV vehicle

Figure 1 shows a XLEV conveyor vehicle. On each corner of the vehicle one recognizes the lower (E-shaped yoke) and the upper (U-shaped yoke) electromagnets. Further on, the vehicle has four short-type homopolar linear motors. This suspension/propulsion combination is chosen in order to have a completely passive track, which is easy to manufacture and does not require any maintenance.

The passive track consists of the reaction rail and the flux guiding pieces, forming the secondary part of the homopolar motor. The vehicle's frame is stiff, its structure is comparable with the structure of a common table. This 'elevated' structure is required in order to pass a passive switch as presented in Figure 2. The inductive energy transmission modules are not depicted in Figures 1 and 2.

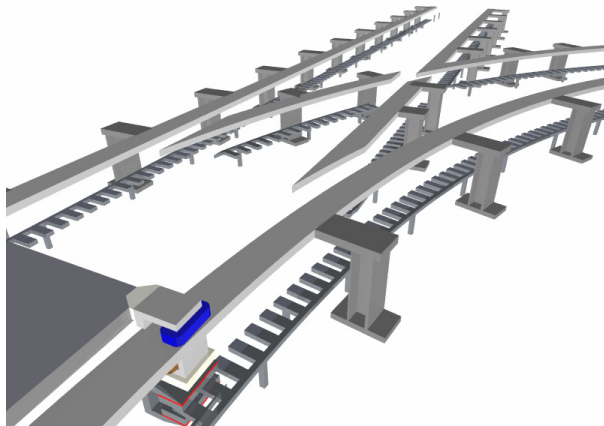

FIGURE 2: The XLEV passive switch

### 3. XLEV SYSTEM DESIGN ASPECTS

The design of the XLEV system is based upon the constraints on the track geometry, in particular the passive switch geometry. Radius of curve/switch and track width form the boundary conditions upon which the further design is based. Figure 3 shows a bird's eye view on the passive switch.

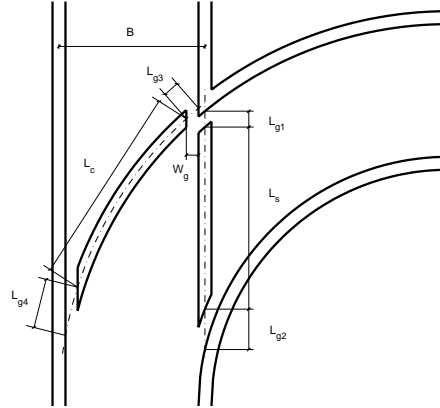

FIGURE 3: Outlines of the XLEV passive switch

In order to prevent the stiff vehicle from interrupting the levitation state, it is necessary, as described below, that at any time three pairs of electromagnets are guided. Thus the dimensions of the vehicle's frame, the electromagnets and the track are matched in such a way that this requirement is fulfilled. Mathematically spoken, this leads to two equations from which the axle-base of the vehicle, defined as the longitudinal distance between two centres of electromagnets, and the length of an electromagnet  $L_{EM}$  can be found based on parameters defined in Figure 3:

$$L_{axle-base} \leq \min(L_c, L_s) - L_{EM} \quad (1)$$

$$L_{axle-base} > \max(L_{g1}, L_{g2}, L_{g3}, L_{g4}) + L_{EM} \quad (2)$$

The different lengths defined in Figure 3 are all correlated with the choice of track width  $B$  and the inner radius of the curve. Based on equations (1) and (2) a first approximative design is made.

### 4. MODE OF OPERATION

#### 4.1 Riding on a rectilinear track

This is the nominal operation mode for the magnetically levitated vehicle. Only the lower magnets are active and enable the levitation state. Hybrid-excited (permanent magnet + coils) magnets are chosen, because they enable a nearly zero power consumption for the levitation function. To achieve this, the air gap set value is adjusted accordingly to the applied load, so

that the support forces caused by the ampere turns of the permanent magnet compensate the total weight of the vehicle. In addition only small ampere turns must be caused by the excitation of the coils for stabilising the system. The vehicle is guided by the reluctance forces of the lower electromagnets. U-shaped yoke electromagnets and a slotted reaction rail result in a lateral stiffness which is sufficient for most conveyor applications. A higher lateral stiffness can be achieved if E-shaped yokes are used.

#### 4.2 Riding through a curve

A high vehicle throughput of the discussed conveyor system is only possible when the curve speeds are sufficiently high. A major advantage of the new XLEV magnetic levitation system is that the guiding forces can be actively controlled without the need for additional guidance electromagnets and its associated expensive air gap measurement system.

Just before the vehicle enters the curve the (upper) stabilising electromagnets are magnetised. This actually means adding a virtual load to the vehicle. In order to continue the levitation state the lower electromagnets must be magnetised stronger, thereby increasing the magnetic induction in the air gap which results in higher reluctance forces. The ampere turns of the stabilising electromagnets fix the additional amount of reluctance force needed for guiding the vehicle through the curve with the assigned curve speed.

A comparison of the guidance force for the conventional and the XLEV system is shown in Figure 4. The stabilising magnet has the same dimensions as the hybrid-excited electromagnet (nominal load: 250 N) but has no permanent magnets. If the stabilising magnet generates an virtual load of 350 N, the guidance force increases by at least a factor three.

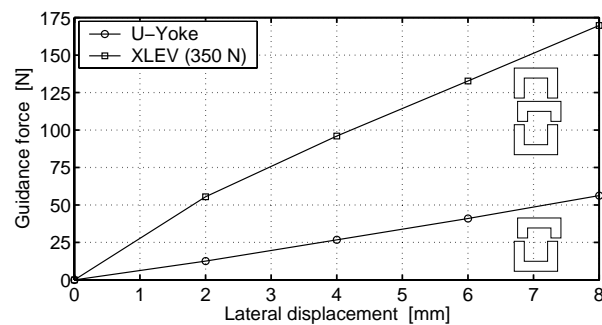

FIGURE 4: Comparison of the guidance force

#### 4.3 Passing a switch

To explain how the XLEV vehicle passes a passive switch without interrupting the levitation state an example situation is analysed. In Figure 5 a bird's eye view on the vehicle positioned before the switch is depicted.

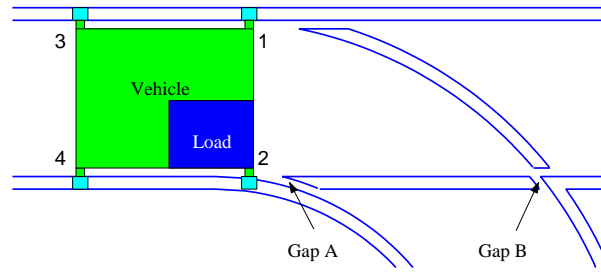

FIGURE 5: Vehicle before passing the switch

The ride straight ahead through the passive switch is considered. The magnet pairs 1 and 3 are guided all the time so there exist no problem here. If corner 2 passes gap A, it can no longer generate a support force because the reaction rail fails. As the vehicle is loaded on the front right corner, the vehicle's centre of gravity is outside the triangle built up of the corners 1, 3 and 4. The weight of the vehicle makes that the vehicle twists around the diagonal 1-4, making that the lower electromagnet of corner 3 will collide with the reaction rail, thereby ending the levitation state. This is not allowed and that is the main reason for the use of the (upper) stabilising magnets.

By proper excitation of the stabilising magnet of corner 3, the twisting of the vehicle can be prevented and the vehicle can pass the switch without interrupting its levitation state. After corner 2 has passed gap A, corner 4 will pass gap A. Depending upon the exact position of the vehicle's centre of gravity with regard to the triangle built up out of the corners 1,2 and 3, excitation of the stabilising magnet of corner 1 may or may not be needed. After corner 4 has passed gap A, for a short period of time the right side of the vehicle is positioned on the linear switchblade. All four magnet pairs are guided and they each contribute their part to the total support force, just as before the passing of the switch. After that the right side of the vehicle will pass gap B through a similar procedure.

### 5. SIMULATION ENVIRONMENT

In order to investigate the dynamic behaviour of the vehicle during the passing of the switch an appropriate dynamic model of the vehicle is build [2]. In a first approach the vehicle is modeled as a rigid body with 6 degrees of freedom.

The equations of motion are analytically derived based on the Newton-Euler formalism with help from the symbolic computation software Maple. Two coordinate systems are used: an inertial coordinate system in which the guideway is defined and a local coordinate system fixed to geometrical centre of the

vehicle. The 6 degrees of freedom are combined in the vector of generalised coordinates  $Y$ :

$$Y = [x, y, z, \alpha, \beta, \gamma]^T \quad (3)$$

The coordinates  $x$ ,  $y$  and  $z$  locate the local coordinate system in the inertial coordinate system. The angles  $\alpha$ ,  $\beta$  and  $\gamma$  (Euler angles) describe the rotation of the local coordinate system about the inertial coordinate system. The equations of motion are set up in the inertial coordinate system. The conveyor vehicle belongs to the class of the ordinary ideal mechanical systems. These are characterised by holonomic constraints and external forces which are only dependent on position and velocity parameters. The corresponding equations of motion can always be written as a system of ordinary differential equations of second order [3]. The vehicle's equations of motion summarised in a matrix equation are:

$$M(Y, t) \cdot \ddot{Y}(t) + k(Y, \dot{Y}, t) = g(Y, \dot{Y}, t) \quad (2)$$

with:

- $M(Y, t)$  the symmetric [6x6] mass matrix
- $k(Y, \dot{Y}, t)$  the [6x1] vector of generalised gyroscopic forces
- $g(Y, \dot{Y}, t)$  the [6x1] vector of generalised forces

In the block diagram of the simulation environment (Fig. 6) the mechanical model is displayed as a black box with the external forces as input parameters and the generalised coordinates as the output parameters. Models of the different electromagnets and the linear drive with the corresponding controller systems complete the modular simulation environment which is implemented in *Matlab/Simulink*.

Each (lower) electromagnet is controlled by its own levitation controller. This decentral control layout mirrors the flexibility in changing the number of active independent control loops. As shown in Figure 7, a linear PI-state controller scheme [4] is used for the different voltage-controlled electromagnets. Air gap

deviation, air gap deviation velocity, coil current deviation and the integrated error signal are the elements of the state vector.

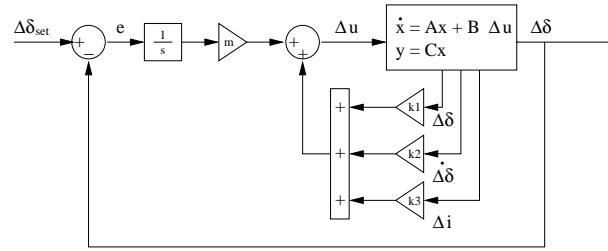

FIGURE 7: PI-state controller

## 6. SIMULATION RESULTS

The simulated vehicle has a empty weight of 100 kg and is loaded with a 25 kg mass on front right corner. The wheel track and axle-base of the vehicle are both 1m. The inner radius of the switch is 1,5m. As in section 4.3 a ride straight through the switch (see Fig.5) is analysed.

Before a hybrid-excited magnet passes the gap, its support force is reduced by negative excitation. In order to guarantee the levitation state, a redistribution of forces on the remaining three magnets is necessary. The reduction in support force of one magnet guarantees only small air gap deviations if the unloaded magnet passes the gap.

The redistribution of forces is based on the force distribution valid before the vehicle enters the switch. This is illustrated for corner 2 passing gap A in Figure 8. Figure 8.a shows the forces of the (lower) hybrid-excited magnets  $F_{u,i}$ , Figure 8.b the forces of the (upper) stabilising magnets  $F_{o,i}$ . Before entering the switch the forces are given by:

$$\begin{aligned} F_{u,1} &= 311 & F_{u,2} &= 382 \text{ N} & F_{u,3} &= 236 \text{ N} & F_{u,4} &= 298 \text{ N} \\ F_{o,1} &= 0 \text{ N} & F_{o,2} &= 0 \text{ N} & F_{o,3} &= 0 \text{ N} & F_{o,4} &= 0 \text{ N} \end{aligned}$$

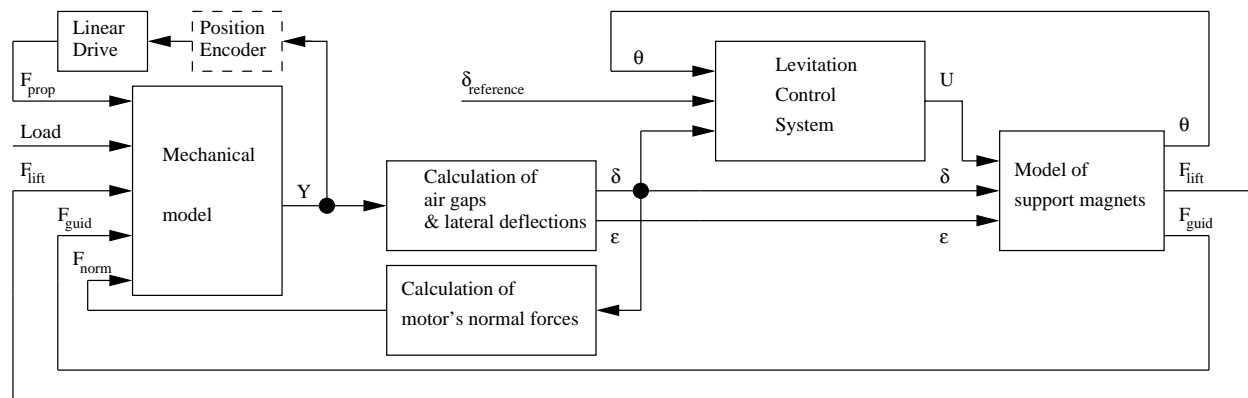

FIGURE 6: Block diagram of the simulation environment

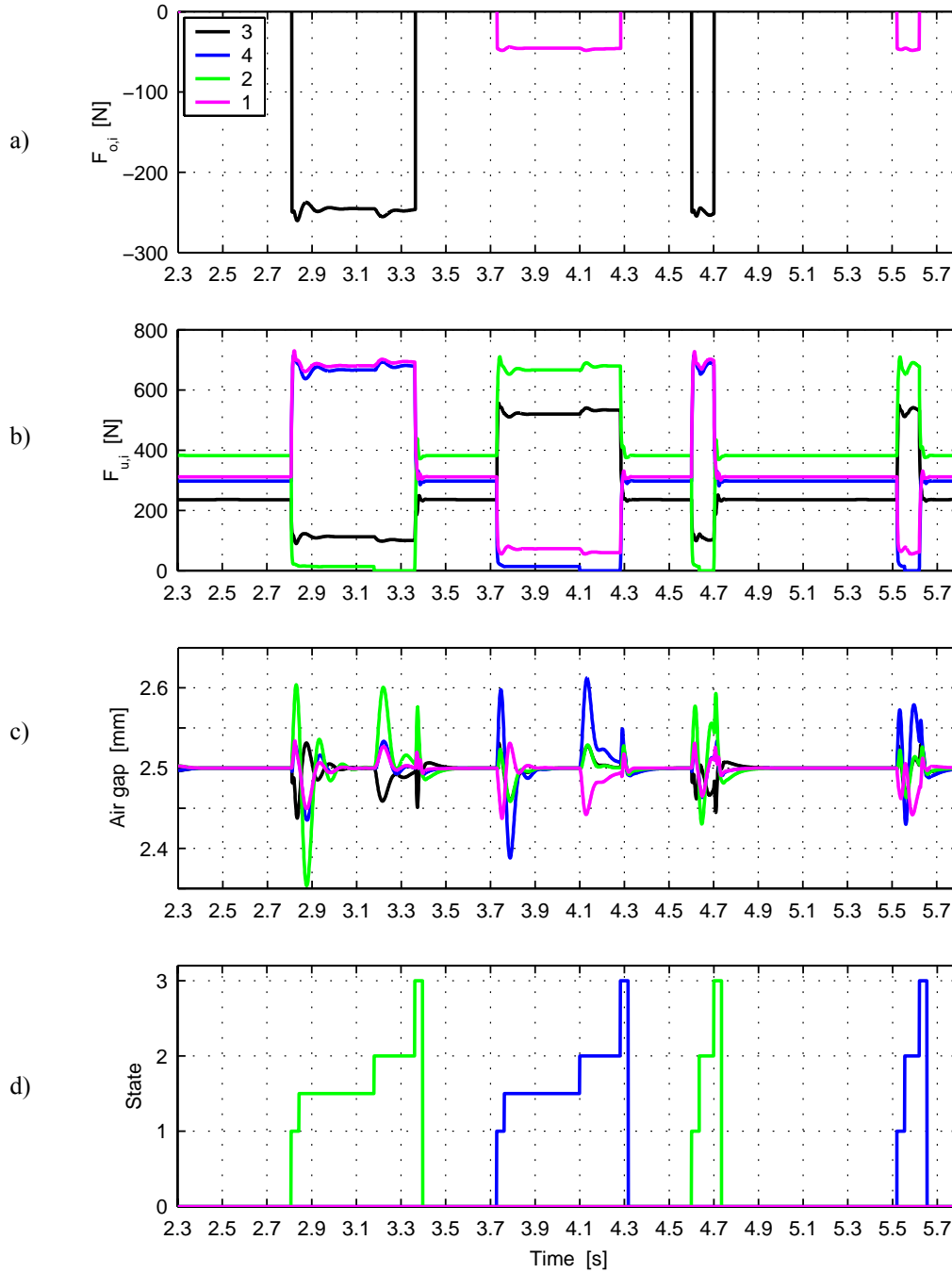

FIGURE 8: Simulation results

A new force distribution enables the nearly perfect unloading of corner 2. It comes about as follows:

$$\begin{aligned}
 F'_{u,1} &= F_{u,1} + \Delta F_u = 680 \text{ N} & F'_{u,2} &= F_{u,2} - \Delta F_u = 13 \text{ N} \\
 F'_{u,3} &= F_{u,3} - \Delta F_u + \Delta F_o = 112 \text{ N} & F'_{u,4} &= F_{u,4} + \Delta F_u = 667 \text{ N} \\
 F'_{o,1} &= 0 \text{ N} & F'_{o,2} &= 0 \text{ N} \\
 F'_{o,3} &= -\Delta F_o = -245 \text{ N} & F'_{o,4} &= 0 \text{ N}
 \end{aligned}$$

Through simultaneous and correctly signed alloca-

tion of the force difference  $\Delta F_u$  on the four hybrid-excited magnets, the affinity of the vehicle to sink or twist is greatly reduced. Additionally, excitation of the stabilising magnet of corner 3 prevents that its lower electromagnets hits the reaction rail. Based on the forces  $F_{u,i}$  of the concerned vehicle's diagonal,  $\Delta F_o$  is calculated as follows:

$$\Delta F_o = (K_1 + (F_{2,u} - F_{3,u})) K_2 \quad (K_1=50, K_2=1,25)$$

$K_1$  and  $K_2$  are safety factors which guarantee that also in marginal cases (e.g.  $F_{2,u} = F_{3,u}$ ) a twisting of the vehicle is prevented.

The unloading process of a corner is implemented as follows: the presented algorithm calculates the new values for  $F'_{u,i}$  and  $F'_{o,i}$ . Because the set of characteristic force curves of the different magnets is stored in the controller, it is easy to find the needed current value which will produce the desired force ( $F'_{u,i}$  or  $F'_{o,i}$ ) for the giving reference air gap value. Because current and voltage are combined by ohms law, it is straightforward to find the new value of the reference voltage  $u_i$  (see Fig. 7). Resetting the initial value of the controllers integrator (see Fig. 7) to this value causes the unloading of the corner.

As can be seen in Figure 8.c only small air gap deviations occur during an unloading process. The phase signal depicted in Figure 8.d provides information upon the actual state of the (lower) magnet. The different descriptions are given in Table 1.

| State | Description                     |
|-------|---------------------------------|
| 0     | controlled magnet               |
| 1     | unloading the controlled magnet |
| 1,5   | controlled magnet is unloaded   |
| 2     | magnet positioned in a gap      |
| 3     | loading the controlled magnet   |

TABLE 1: States of a magnet

Before corner 2 encounters gap A (see Figure 8.d), the corresponding magnet remains in state 1,5 for a while. This is necessary because the guidance force of this magnet counteracts the straight ahead ride of the vehicle. By unloading the magnet, its guidance force will be small and the resultant guidance force (magnet 1 and 2 together) will steer the vehicle in the wanted direction. At  $t \approx 3,2$  s magnet 2 enters the gap and the residual support force  $F'_{u,2}=13$  N breaks off. After passing the gap, the magnets are excited just as in the initial phase of the simulation. Therefore, the initial conditions of the integrators are reset to the initial values of  $u_i$ , which are stored before entering the switch. Temporally delayed, corner 4 passes gap A. Subsequently, a similar procedure takes place to pass gap B. The smaller length of this gap explains the faster crossing of this gap. This time no wrong directed guidance forces occur, so state 1,5 does not show up.

## 7. CONCLUSION

In this paper the novel XLEV magnetic levitation system is presented. In order to investigate the dynamic behaviour, an appropriate simulation environment is discussed and simulation results of a ride through a

passive switch are given. These results prove that a vehicle equipped with the XLEV suspension system is able to pass a passive switch without interrupting the levitation state. Also is shown that the guidance force of the XLEV vehicle can be actively controlled without the need for guidance magnets. Because of the completely contactless operation of the XLEV system a conveyor system characterised by a high operational availability together with a high conveyor speed can be built. Further investigation will focus on the implementation of a test bench.

## REFERENCES

- [1] J. Van Goethem, G. Henneberger, "XLEV: a Novel Magnetic Levitation System for a conveyor Vehicle", Proceedings of the 4. International Symposium on Linear Drives for Industry Applications, LDIA 2003, Birmingham, UK, S. 137-140, 2003
- [2] J. Van Goethem, L. Schober and G. Henneberger, "Design and Simulation of a Magnetic Levitation Conveyor Vehicle", Proceedings of the 7. International Conference on Modelling and Simulation of Electric Machines, Converters and Systems, ELECTRIMACS 2002, Montreal, Canada, Conference CD, 2002
- [3] K. Popp and W. Schiehlen, "Fahrzeugdynamik ", B.G. Teubner Stuttgart, 1993, pp. 80-86
- [4] J. Van Goethem, G. Henneberger, "Design and Implementation of a Levitation-Controller for a Magnetic Levitation Conveyor Vehicle ", Proceedings of the 8. International Symposium on magnetic bearings, ISMB 2002, Mito, Japan, S. 139-143, 2002